



BOLTON
FURNITURE

**249 Professional Drive
Morrisville, VT 05661**

Tel: 802-888-7974

Fax: 802-888-3668

Website: www.vtprecision.com

**Assembly Sheet
for B-1, B-2, Twin over Full
Bunk Bed / Twin Bed**

Parts List

Bunk Beds:

A bunk bed is made up of two twin beds.

(2) headboards, (2) footboards, (4) side rails,

(1) angle ladder, (2) guard rails, (2) slat boxes which include (14) slats each (do not remove the webbing strips from the slat roll).

(2) Twin Bed packages includes: (8) 3 1/4" Allen head bolts, (1) Allen wrench, (8) barrel nuts and (28) #8 wood screws for the bed slats.

(1) Guard Rail / Ladder package includes: (2) ladder brackets, (6) 3/4" x #8 wood screws, (4) steel pins and (4) 1-1/4" x #8 wood screws (located in the bunk ladder box)

Certain styles of bunk beds come with 4 finials (check with your Vermont Precision Woodworks dealer for styles), additional finials can be purchased from your Vermont Precision Woodworks dealers.

Bunk Bed Assembly:

Bunk beds consist of two twin beds; use both headboards (with the holes drilled in the tops of the legs) for the bottom bed and both footboards for the upper bed.

1) Insert the barrel nuts into the holes in the inside of the side rails with the slot for the screwdriver facing out, as shown in the diagram.

2) Attach the side rails to the headboards. Insert the Allen head bolts through the two upper holes in a leg of the headboard and into the barrel nuts in the end of the side rails (see diagram). Tighten the bolts with the enclosed Allen wrench. Attach both side rails to one end and then repeat for the other side. Do not tighten the joint connector bolts completely until all hardware is in place.

3) Place the (4) steel pins (located in the bunk ladder box) into the holes in the tops of the headboard legs. Place the footboards on top of the steel pins.

4) Attach the side rails to the footboards to complete the upper bed frame again using the two upper holes. Once the bed is completely assembled, tighten the Allen head bolts completely.

5) Place the slat roll on top of the wooden cleat and secure by using all #8 wood screws. Make sure that the spacing between each bedend and first slat is no more than 3 1/2 inches. Note: The webbing should be on the top.

6) Guard Rails: There is a separate package of hardware located in the bunk ladder box. Both guard rails must be installed and secured to the siderails with the hardware provided. First find the pre-drilled holes on the bottom of the post make sure the holes are placed facing to the inside of the bed. Position the guard rails in the center of the siderail and secure using the #8 wood screws provided. Tighten the screws completely. Repeat for the second guard rail.

ATTACHMENT OF ANGLE LADDER: First attach each bracket included, using (2) 3/4" x #8 screws provided in the pre-drilled holes of the ladder. (Ladders are not to be used on the ends of the bed to climb over the bed end structure). To install the ladder, hook the top part of the bracket on the side rail by holding the base of the ladder away from the bed. Tighten the ladder by screwing a 3/4" x #8 wood screw into siderail through the short end of hook. Now the ladder cannot be inadvertently dislodged while someone is climbing to or from the top bunk.

Twin Bed Assembly:

Complete steps 1 and 2 above using a headboard and footboard. Use upper set of side rail holes unless using a boxspring, then use the lower set of holes. Attach slat roll as indicated in step 5 above.

Safety Warnings:

- 1) Follow the information on the warning label attached to the upper bunk end structure. Do not remove this label.
- 2) Always use the recommended size mattress to help prevent the likelihood of entrapment or falls. Use a mattress which is 75" long and 38 1/2" wide on the top bunk.
- 3) Surface of mattress must be at least 5 inches below the upper edge of the guard rails. Ensure thickness of mattress and foundation combined does not exceed 8".
- 4) Do not allow children under 6 years of age to use the upper bunk.
- 5) Prohibit more than one person on the upper bunk.
- 6) Periodically check to ensure that the guard rails, ladder, and other components are in their proper position, free from damage, and that all connectors are tight.
- 7) Do not allow horseplay on or under the bed and prohibit jumping on the bed.
- 8) Always use the ladder for entering and leaving the upper bunk.
- 9) Do not use substitute parts. Contact the manufacturer or dealer for replacement parts.
- 10) Use of a night light may provide an added safety precaution for a child using the bunk.
- 11) If the bunkbed will be placed next to a wall, the guard rail that runs the full length of the bed should be placed against the wall to prevent entrapment.
- 12) Always use guard rails on both sides of the upper bunk.
- 13) The use of water or sleep flotation mattresses is prohibited.
- 14) Keep these instructions for future reference.

STRANGULATION HAZARD

- 15) Never attach or hang items to any part of the bunk bed that are not designed for use with the bed for example, but not limited to hooks, belts, and jump ropes.

Replacement parts, including additional guardrails may be obtained from any of our Bolton Furniture or Vermont Precision Woodworks dealers.

VERMONT PRECISION WOODWORKS
ASSEMBLY INSTRUCTIONS



Bracket Assembly

Attach each ladder bracket using (3) 3/4" x #8 wood screws as shown above.

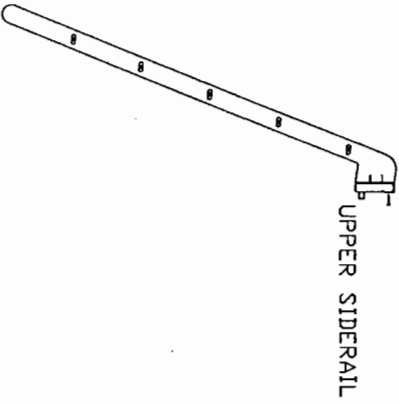

Attaching the Ladder

Step 1: Attach ladder and long end of hook by using 2 3/4" x #8 wood screws, hook the top part of the bracket onto the upper siderail.

Step 2: Lower the bottom of ladder to the floor and screw 1 3/4" x #8 wood screw into siderail through short end of hook.

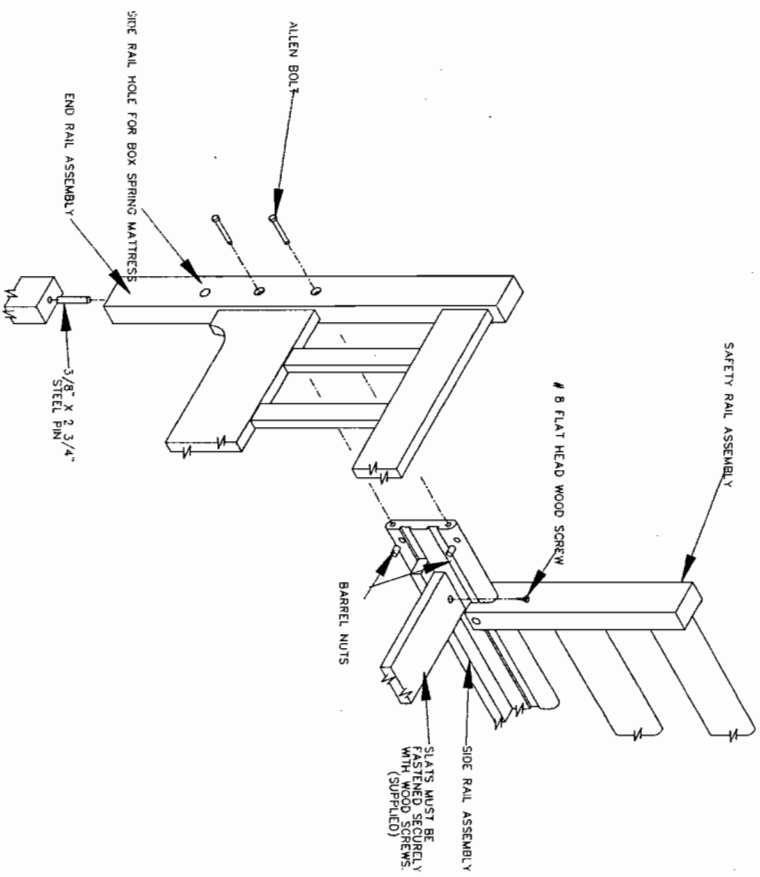

Bed Assembly

Tools Necessary for Assembly:

Allen wrench (included), a Phillips screwdriver and a Flat tip screwdriver.